

# Techniques to Reduce Measurement Errors in Challenging Environments

**Jon Semancik**  
**VTI Instruments Corp.**  
**2031 Main Street**  
**Irvine, CA 92614**  
**949-955-1894**  
[jsemancik@vtiinstruments.com](mailto:jsemancik@vtiinstruments.com)

## INTRODUCTION

Test engineers face a unique set of challenges when measuring temperature, strain, pressure and flow in or near a test article in electrically noisy or hazardous environments. To address these issues, they often employ a centralized approach that involves placing data acquisition instrumentation in a control room located some distance from the test article. Transducers are then connected to the test article with cabling that can result in significant installation and ongoing maintenance expenses.

A centralized approach provides convenient control room access to the signal conditioning and instrumentation, but also creates unintentional measurement error. Errors introduced from long cable lengths include electrical noise, calibration uncertainty, bridge excitation uncertainty, and cable impedance. Additionally, this topology has significant cost drivers associated with implementation such as cabling, debugging, maintenance, and setup.

To improve measurement accuracy, test engineers employ a distributed measurement philosophy by placing the instrumentation near the test article. Programmable internal signal conditioning on each channel eliminates the need for external cabling, which can result in lower measurement quality, increased setup time, and additional maintenance. A distributed topology protects against adjacent channel over-voltage and noise interference that occurs when measurements are made utilizing common filter circuitry, as seen in scanning DMM architectures.



**Figure 1. Example of distributed measurement application**

Distributed measurement systems must also include a convenient mechanism for in-place self-calibration, as well as NIST-traceable calibration. Complete end-to-end internal self-calibration provides significant accuracy improvements over other test configurations. Self-calibration compensates for circuitry drift that has occurred since the last full calibration and is relatively easy to perform.

While employing distributed measurement techniques can simplify setup and improve overall performance, they also introduce a new set of challenges including synchronization, timing, and data management. LXI (LAN eXtensions for Instrumentation) has emerged as the next generation instrumentation interface and resolves many of these issues. LXI is based on Ethernet technology, the most commonly used open platform communications interface.

LAN synchronization that incorporates the IEEE-1588 Precision Time Protocol (PTP) enables multiple devices to be synchronized utilizing a single LAN Ethernet connection. PTP defines a precision clock synchronization protocol for networked measurement and control systems that is designed to enable the synchronization of systems that include clocks of different precision, resolution and stability. The most accurate and deterministic synchronization mechanism between multiple devices involves the implementation of a hardware trigger interface. As a result, the LXI standard also defines a high-performance trigger interface referred to as the Trigger Bus, which can provide the link between all devices in the test system for both triggering and clock signal distribution.

While distributed data acquisition solutions simplify some aspects of the test process, they also pose new challenges that were relatively transparent in previous generations of hardware. This paper will discuss these challenges and the innovative approach that instrumentation designers have adopted to make full-featured, distributed data acquisition a reality.

## **DISTRIBUTED DATA ACQUISITION**

Distributed measurements offer numerous advantages over traditional centralized methods and have become increasingly popular, especially in data acquisition applications. Advances in electronic component designs and packaging along with the introduction of the LXI interface standard have provided the basis for a powerful new generation of instrumentation.

The strategic placement of data acquisition instrumentation around or near the test article can result in significant advantages. The benefits of this approach include:

- Quick setup
- Simplified calibration and maintenance
- Excitation source closer to bridges
- Reduced cabling costs and noise
- Minimized debugging
- Improved transportability

The above benefits encompass the entire operational life of a project including installation, maintenance, support, and calibration. Cost savings begin at the time of installation by greatly reducing the cost of cabling and associated installation, debugging and testing. Simplified calibration and excitation further improves system performance. Reducing the effects of noise on transducer cables and simplifying calibration increases overall accuracy.

## **SYSTEM CALIBRATION**

It is critical for test engineers to confidently rely on the integrity of the data produced by their measurement devices. This confidence is primarily achieved through instrument calibration and traceable verification standards. Specifically, a traceable source is used by the instrument undergoing calibration to adjust and verify the quality of the measurement. This has often been viewed as a painful but necessary process involving system disassembly and downtime.

In most cases, test engineers are required to disassemble test stations and send each instrument to its respective vendor's factory for calibration. Some costly alternatives include ordering spare instruments for each test station, hiring an outside calibration service, or constructing an in-house calibration laboratory. Reducing these costs and alleviating the downtime associated with the calibration process ultimately benefits all test and measurement applications.

VTI's integrated data acquisition signal conditioning systems are designed to simplify the calibration process and have added features that guarantee measurement accuracy. By taking advantage of the distributed measurement benefits of LXI and designing instruments with on-board precision voltage references, calibration becomes more convenient and reliable. The LXI standard allows vendors to embed an easy-to-use calibration process directly into the instrument's firmware, allowing the end user to execute a complete calibration in minutes, at the click of a button. A

precision on-board voltage source can extend the calibration capabilities by also offering a self-calibration routine, which the end user can initiate at any time. This procedure guarantees the most precise measurements, regardless of environmental changes.

A fully integrated web interface streamlines the calibration process, making it more convenient and cost effective. To perform a complete NIST-traceable calibration, a host computer and precision voltmeter are required. Simply connect the voltmeter to the instrument utilizing banana jacks, access the web interface using a standard Internet browser, and click the button that commands the instrument to perform the automatic factory calibration.

The instrument's firmware can be configured to recognize and communicate with several different voltmeters to measure the on-board precision voltage source. While storing this value, the instrument can route the source back through the input signal paths and reliably perform internal adjustments. When compared to other methods, this requires little user interaction and no calibration software development. The simplified equipment setup enables the process to be executed almost anywhere. For example, instead of sending the instrument to the metrology lab, test engineers can send the metrology lab to the instrument.

Prior to each data acquisition sequence, the device can execute a self-calibration procedure directly from the software or a web browser interface. Before any measurement is taken, users can initiate a self-calibration sequence that routes the precision source back through the actual input signal path. Whenever the device undergoes changes in its surrounding thermal environment, this process can be executed to ensure the highest degree of measurement quality.

## **LAN SYNCHRONIZATION**

LAN synchronization, incorporating the IEEE-1588 Precision Time Protocol (PTP), highlights another fundamental advantage of LXI Class B devices that is ideal for distributed measurements. This completely over-the-wire approach provides an ideal mechanism to synchronize multiple instruments separated by hundreds or thousands of meters.

PTP defines a precision clock synchronization protocol for networked measurement and control systems. The protocol is designed to enable the synchronization of systems that include clocks of different precision, resolution and stability. Sub-microsecond accuracy can be achieved with minimal network and local clock computing resources, and with little administrative attention from the user.

There are several ways in which PTP can be implemented ranging from user-level software control, to kernel-level driver modifications, to hardware implementations utilizing dedicated FPGA devices. The highest level of precision is obtained when hardware implementations assist in the time stamping of incoming and outgoing network packets or frames, which can result in delay fluctuations that are within the nanosecond range. PTP provides multiple device synchronization while eliminating the need for external cabling between devices. This approach is less accurate than hardware triggering. However, Gigabit Ethernet can provide synchronization times in the hundreds of nanoseconds range, which may be suitable for slower data acquisition rates common with thermocouple measurements.

Below are examples of PTP implementations and the associated relative synchronization accuracy comparisons (see Figures 2–4 and Table 1).

## IEEE1588 via Software

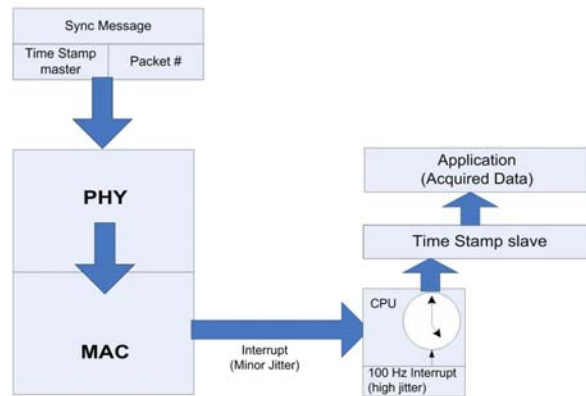

Figure 2

## IEEE1588 via Software w/ Hardware Assist

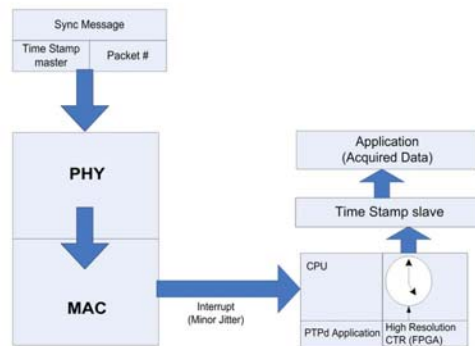

Figure 3

## IEEE1588 Hardware Snoop

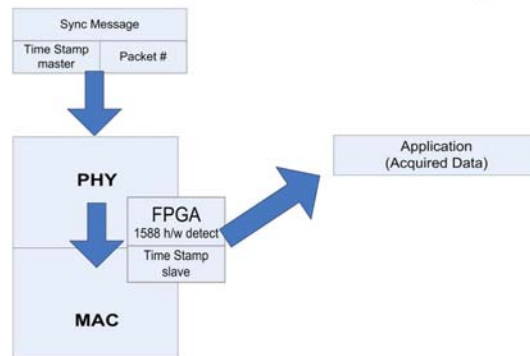

Figure 4

## IEEE1588 Synchronization Accuracies

IEEE1588 Mechanism	Relative Master/Slave Delta
Hardware Snoop	10-20 nanoseconds
Software Only	10-100 milliseconds
Software w/ Hardware Assist	10 microseconds

Table 1

## HARDWARE SYNCHRONIZATION

IEEE-1588 provides incredible advances in over-the-wire synchronization; however, there will always be instances where additional accuracy is required. The most accurate and deterministic synchronization mechanism between multiple devices involves the implementation of a hardware trigger interface. As a result of this requirement, the LXI standard defines a high-performance trigger interface referred to as the Trigger Bus. The LXI Trigger Bus is required in LXI Class A devices and provides the link between all devices in the test system for both triggering and clock signal distribution.

Deterministic trigger generation and propagation between multiple devices is accomplished with an eight-channel, multipoint-low-voltage differential signal (M-LVDS) interface. This architecture permits individual lines to be configured as a source and/or receiver while supporting external time-based or software-generated triggering and clock distribution. Common topologies including star, daisy-chain, and hybrid configurations are supported. They provide the flexibility to distribute the trigger lines as dictated by the application requirements. Additional flexibility is realized with the addition of a star hub, which permits very tight trigger tolerances to be maintained throughout a large distribution network (see Figure 5).

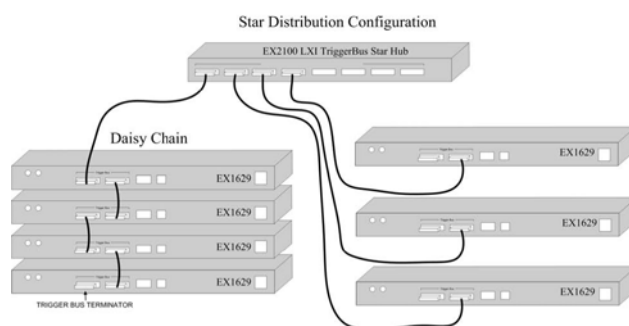

**Figure 5. Trigger Bus Signal Distribution**

Many data acquisition applications require a large number of parallel-channel instruments to be synchronized to a common clock or trigger pulse. Furthermore, the clock signals are often linked to a system clock such as IRIG-B or GPS for overall time correlation. The Trigger Bus interface simplifies the process of distributing these signals and ensures low channel-to-channel skew when proper cabling and interconnects are used.

## INTEGRATED SIGNAL CONDITIONING

To properly utilize distributed instrumentation, all aspects of the measurement device must be made available at the point of placement. Therefore, features such as cold junction compensation, filtering, shunt calibration, and transducer excitation must all be accessible from and integrated into the remote instrumentation.

The thermocouple is one of the most commonly used temperature measurement devices. Thermocouple transducers generate a low-level voltage when two dissimilar metals are placed in contact with one another. This voltage is commonly referred to as thermal electromotive force and the signal is in the microvolt-level range. For example, a Type-K thermocouple will generate 39 $\mu$ V at 1°C with a full scale operational range of approximately 60 mV.

Gain stages are implemented to ensure that the signal is amplified to a level where fine changes in temperature can be resolved. A gain of 100 would amplify a 1200°C Type-K thermocouple (48.838 mV) input to a level of 4.8838 V. Without the necessary gain stages, the measured signal will have significantly less resolution and be more susceptible to noise fluctuations.

Since microvolt-level signals are also very susceptible to the effects of 60 Hz interference, the instrumentation must

provide significant bandwidth limiting for rejection purposes. This is particularly important in industrial environments where the thermocouple is exposed to significant electrical noise from motors, generators, welding devices, lighting and other sources.

Many thermocouple measurement devices, such as DMM-based systems, provide some level of programmable 60 Hz rejection. However, this bandwidth limiting is achieved through the setting of the ADC integration rate. Specifically, 60 Hz rejection is improved by integrating over an integer number of power line cycles (PLC). This approach may reduce the effects of 60 Hz noise, but it also results in substantially slower channel sampling rates.

Less accurate PC-based relay multiplexers typically do not offer any analog filtering and rely on averaging or other software techniques to manipulate data. This can present difficulties when accurate, clean data is required across the measurement spectrum. It may become necessary to add external filtering circuits in an effort to improve signal integrity. While this may result in lower noise, it may also increase system cost and complexity.

The EX1000A precision thermocouple and voltage measurement instrument series does not rely on the ADC to provide bandwidth limiting or on software over-sampling and averaging techniques. Instead, bandwidth limiting occurs in each channel's signal conditioning path, which permits the channel to be independently set to a specific cutoff frequency.

A flexible approach allows for multiple cutoff frequency ranges that typically span between 4 Hz and 1 kHz bandwidth. For many thermocouple and low-level voltage measurements, 4 Hz is a suitable cutoff frequency since it maximizes the 60 Hz rejection. However, there are instances when multiple cutoff frequency selections are useful. Higher cutoff frequency selections work well for fine gauge thermocouples and high-speed voltage measurements (see Figure 6).

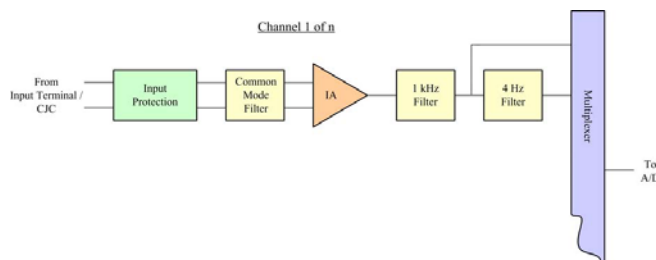
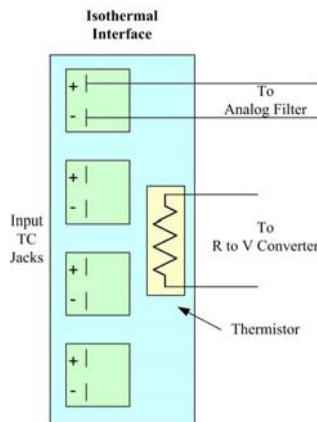

**Figure 6. EX1000A Series independent signal path and filtering**

The cold junction compensation (CJC) circuit is at the heart of any truly accurate thermocouple measurement instrument. Even an isothermal block with significant thermal mass will slowly change temperature in phase with the ambient surroundings. Therefore, measurement errors are guaranteed if these effects are underestimated or incorrectly addressed, especially when the instrumentation is distributed.

The accuracy of a typical multiplexer PC card and DMM-based system is about 1.0° to 1.5°C. Factors that may reduce accuracy include low thermal mass isothermal blocks, incorrect/insufficient CJC sensor placement, and terminal blocks located too close to adjacent heat sources such as power supplies and displays. Poorly designed CJC sensor circuits and input-to-CJC thermal coupling mechanisms can also cause errors.

Precision temperature measurement instruments incorporate multiple high-precision CJC mechanisms, significant thermal mass, careful placement of parts that generate internal temperature gradients, and self-calibration. The CJC sensor is typically a precision thermistor device that can be located at strategic points on the isothermal block. Higher channel count systems will also incorporate multiple isothermal blocks (with additional thermistors) to eliminate gradients at different connection points (see Figure 7). Considering these factors, a system-level measurement accuracy of 0.2°C to 0.4°C is possible.

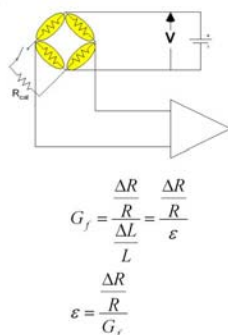

**Figure 7. EX1000A Series CJC isothermal interface**

Many of the issues affecting thermocouple measurements also impact distributed bridge measurements. Unlike thermocouples that generate a voltage based on a dissimilar metal junction, bridge devices require excitation sources, bridge completion resistors, and shunt calibration capabilities.

Test engineers must be able to remotely access and program a distributed measurement instrument to perform shunt calibration or modify the type of bridge completion required without sending a technician to each location. Shunt calibration can quickly provide the user with a high degree of confidence relative to the integrity of the transducer and associated cabling (see Figure 8).

### Integrated Shunt Calibration



**Figure 8. EX1629 sample shunt calibration calculation**

Ensuring that the excitation voltage is accurate is another key to obtaining valid strain measurements. The EX1629 incorporates built-in excitation and provides independent ADC circuitry to measure its voltage. Conversion to micro-strain is then accomplished by utilizing the actual measured value at the transducer, resulting in more accurate measurements.

## CONCLUSION

Distributed data acquisition implementations can greatly simplify the end user's installation and maintenance as well as provide savings in time and material. For accurate distributed measurements, instrumentation designers must include key functionality such as internal signal conditioning, self-calibration, excitation, and noise rejection.

Developing instrumentation with communication interfaces based on the LAN-based LXI standard will also ensure that Ethernet connectivity and performance are not compromised. Solutions must incorporate Class A support to provide the necessary synchronization and timing functionality. This approach establishes reliable time correlation between thousands of distributed channels with tremendous architectural flexibility.